

MPT03

Lithium-Ion Multi-Purpose Order Picker
max. stand height 3000 mm

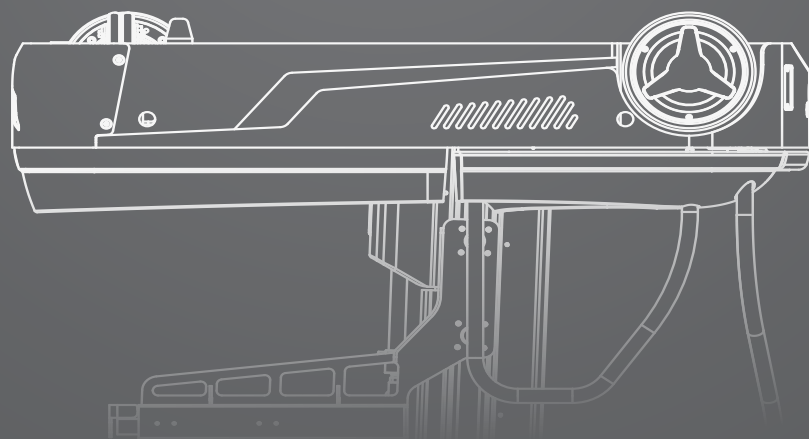
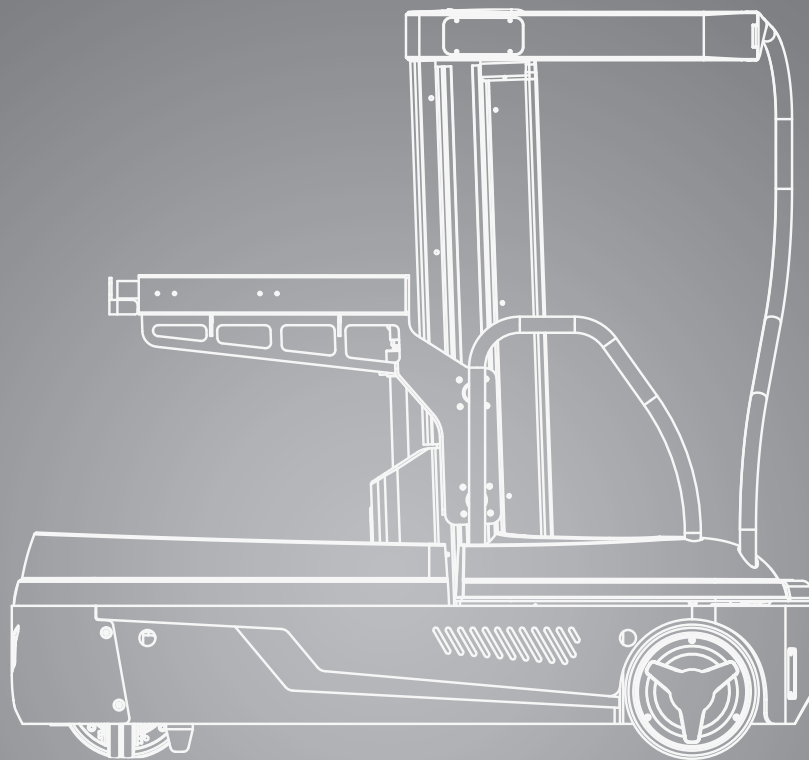

DIMENSIONS

MPT03

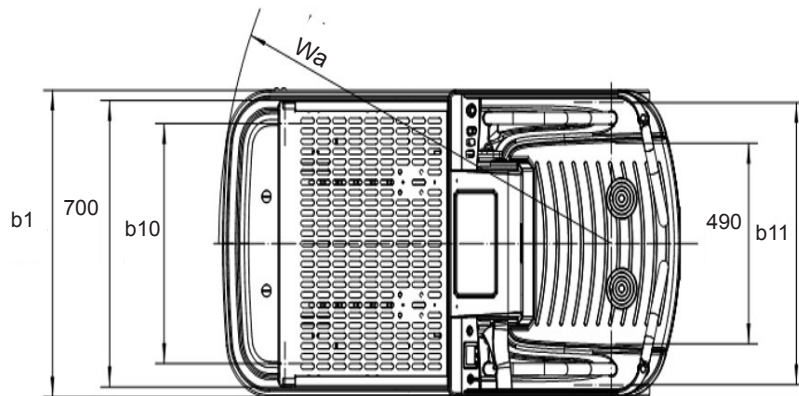
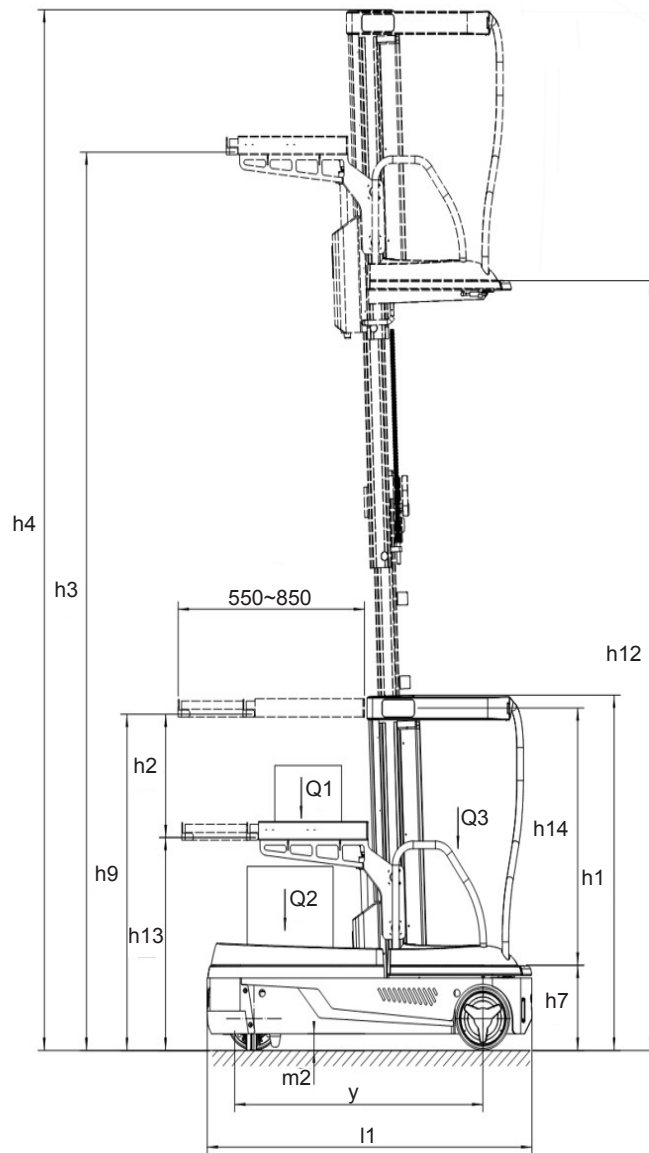

For corresponding data see specification chart.

SPECIFICATIONS

Product specification acc. to VDI 2198

	1.1	Manufacturer (Abbreviation)	CLARK
Specifications	1.2	Manufacturer's designation	MPT03
	1.3	Drive unit	Electric-24V
	1.4	Operator type stand on/driver seated	Stand on Order picker
	1.5.1	Load capacity/rated load	Q1 (kg) 90
	1.5.2	Load capacity/load lower shelf	Q2 (kg) 150
	1.5.3	Load capacity/load operator	Q3 (kg) 130
	1.9	Wheelbase	y (mm) 1058
Weight	2.1	Service weight	kg 730
	2.3	Axle loading, unladen front/rear	kg 340 / 390
Tyres, Chassis	3.1	Tyres	Polyurethane
	3.2	Tyre size, front	Ø 250 x 80
	3.3	Tyre size, rear	Ø 250 x 60
	3.4	Additional wheel (dimensions)	Ø 75 x 23
	3.5	Wheels, number front/rear (x = drive wheels)	1x+4/2
	3.6	Tread, front	b10 (mm) 586
	3.7	Tread, rear	b11 (mm) 690
Dimensions	4.2	Height of mast, lowered	h ₁ (mm) 1415
	4.3	Height, upper shelf	h ₂ (mm) 485
	4.4	Lift *1	h ₃ (mm) 3505
	4.5	max.height of mast, extended	h ₄ (mm) 4065
	4.8	Standing height, driver's cab lowered	h ₇ (mm) 350
	4.9	Height drawbar in driving position min./max.	h ₁₄ (mm) 1016
	4.11	Additional lift	h ₉ (mm) 1340
	4.14	Standing height, driver's cab extended	h ₁₂ (mm) 3000
	4.15	Lowered fork height	h ₁₃ (mm) 855
	4.19	Overall length	l ₁ (mm) 1500
	4.21	Width	b ₁ (mm) 750
4.32	Ground clearance centre of wheelbase	m ₂ (mm) 65	
4.34	Stacking aisle for pallets	Ast (mm) 1880	
4.35	Turning radius	Wa (mm) 1286	
Performance	5.1	Travel speed laden/unladen	km/h 8.2
	5.2	Lift speed laden/unladen	m/s 0.34/0.35
	5.3	Lowering speed laden/unladen	m/s 0.3/0.3
	5.8	max. gradeability laden/unladen (S2 5 min.) *1	% 5/8
	5.10	Service brake	electro magnetic
Drive line	6.1	Drive motor output (S2 60 Min.)	kW 1.2 (DC)
	6.2	Lift motor output S3 15 %	kW 2.2
	6.4	Battery voltage, nominal capacity K5	V/Ah 24/100
	6.5	Battery weight	kg 48
Misc.	10.5	Steering design	EPS
	10.7	Sound level, driver's ear DIN/EN 12053	dB (A) 70

*1 At friction coefficient $\mu=0.6$ with 1.6 km/h

All values shown are for standard lift truck with standard equipment. If the truck is supplied with options, values may change. The specifications apply under normal operating conditions. All values given may vary + 5 % and - 10 % due the motor and system tolerances and represent nominal values obtained under typical operating conditions. CLARK reserves the right to change products and specifications without prior notice.

EQUIPMENT EXTRAS

	Equipment feature	MPT03
General	Low-maintenance drive motor	•
	Proportional lift control	•
	Simultaneous driving and lifting	•
	Colour display	•
	Robust steel frame	•
Battery and Charging Technology	Battery 24 V / 100 Ah (Li-Ion) + Charger 24 V / 50 A (internal)	•
	Battery 24 V / 150 Ah (Li-Ion) + Charger 24 V / 50 A (internal)	x
Safety and Operation	Dead-man switches in the platform floor	•
	Electromagnetic parking brake	•
	Automatic speed reduction at high platform height	•
	External emergency stop	•
	Hydraulic emergency lowering	•
	Turtle mode	•
	LED work light (integrated at the front)	•
	Blue Light warning lights (2 units)	x
	Red warning light (1 unit)	x
	Trailer hitch / towing device	x
	Height-adjustable upper shelf (90 kg)	•
	Lower shelf (150 kg)	•
	Telescopic shelf depth 550–850 mm	•
	Viewing slots for improved floor visibility	•
	Document pocket	•
	Easy-to-grip controls	•
Customisable driving and lift parameters	•	

• = Standard equipment; x = Option

FEATURES & ADVANTAGES

MPT03

Compact and versatile

- Platform height up to 3000 mm (reach height up to 5000 mm)
- Proportional lift control for smooth, precise lifting and lowering
- Shelf capacities: lower shelf 150 kg, upper shelf 90 kg

Operation

- Excellent manoeuvrability: 750 mm (b1) truck width and 1300 mm (Wa) turning radius
- Height-adjustable, telescopic shelf (550–850 mm) with viewing slots
- powerful 1.2 kW drive motor and 2.2 kW lift motor

Operator-friendly

- Simultaneous driving and lifting for efficient workflows
- Colour display near the steering handle
- Low step height 350 mm for quick mounting and dismounting
- Turtle mode for controlled manoeuvring in confined areas

Safety

- Automatic speed reduction at elevated platform positions
- Dead-man switches
- Electromagnetic parking brake and external emergency stop
- Robust steel frame

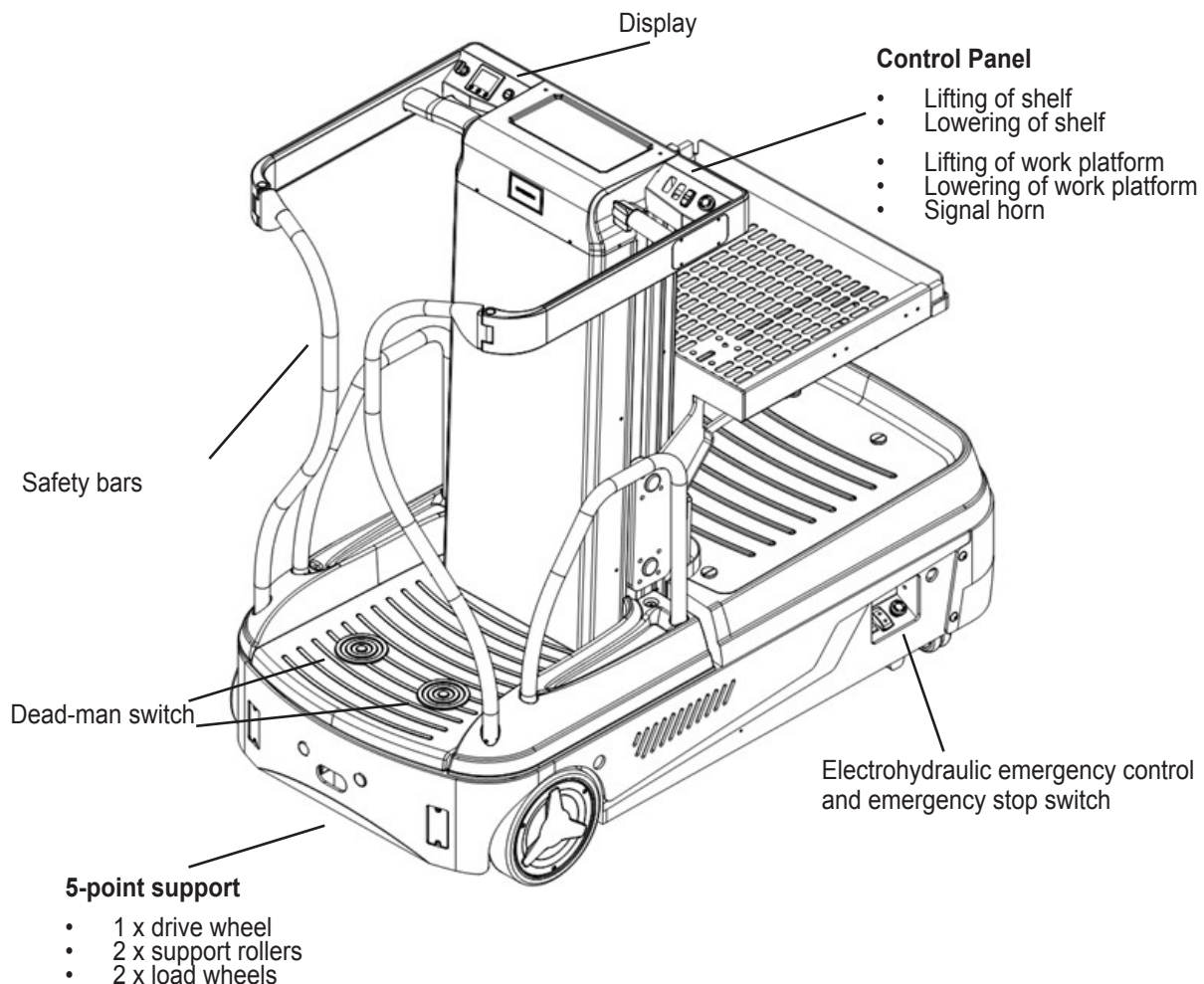

MPT03

The CLARK MPT03 is a compact and versatile multi-purpose order picker, developed for efficient work up to a maximum platform height of 3000 mm (h12). It combines the functions of a mobile workstation, a safe rolling ladder and a height-adjustable work platform in one truck. This makes the MPT03 ideal for order picking, shelf replenishment, maintenance and repair work, as well as many other indoor applications.

The elevating work platform enables safe and ergonomic work at height without the time-consuming and risk-prone climbing of conventional rolling ladders. The operator can drive and lift simultaneously, supporting faster processes and a more efficient workflow.

Thanks to its compact design, high manoeuvrability and intuitive operation, the MPT03 is a reliable solution for retail, warehouses, distribution, facility management, museums, offices, hotels and trade-fair construction - wherever precise manoeuvring and safe access to higher working positions are required.

Work platform

The work platform is designed for safe, ergonomic and productive work at various heights. With a maximum platform height of 3000 mm (h12), the operator achieves an effective picking height of around 4600 mm and a maximum reach height of up to 5000 mm.

Safety Systems

The platform is equipped with automatic locking safety bars to increase operator protection. Two dead-man switches in the platform floor monitor whether the operator is standing securely.

Driving speed is automatically adjusted to platform height to support safe operation at elevated positions. An easily accessible emergency stop provides additional protection against unintentional manoeuvres.

Operator-friendly

The CLARK MPT03 is designed for intuitive and safe operation. An easy-to-read colour display near the steering handle provides clear information on key operating statuses. A proportional lift control is fitted as standard, allowing the work platform to be raised and lowered smoothly and precisely.

The low step height of 350 mm (h7) supports frequent mounting and dismounting and is ideal for tasks with regular height changes. The ability to drive and lift at the same time helps the operator work without interruption and reduces time lost through repeated repositioning.

Excellent manoeuvrability is particularly noticeable in narrow aisles and confined spaces. A turning radius of 1300 mm (Wa) and a compact truck width of 750 mm (b1) support precise manoeuvring even in very tight areas.

Drive & Battery Technology

The CLARK MPT03 is equipped with an efficient 1.2 kW drive motor and a powerful 2.2 kW lift motor. This combination supports strong lifting performance, smooth lift movements and controlled driving - ideal for applications with frequent height changes and short driving distances.

As standard, the MPT03 is equipped with a maintenance-free 24 V lithium-ion battery (100 Ah) for a full working day. An optional 24 V lithium-ion battery (150 Ah) is available for extended operating time. Both battery variants are charged via an internal 24 V / 50 A charger, which can be used with any standard 230 V socket. No special charging rooms or ventilation systems are required.

Dealer:

CLARK Europe GmbH
Dr.-Alfred-Herrhausen-Allee 33
47228 Duisburg / Germany
Tel.: +49 (0)2065 499 13-0
Fax: +49 (0)2065 499 13-290
E-Mail: Info-europe@clarkmheu.com
www.clarkmheu.com