

RSE16

Lithium-Ion Stacker Truck
with platform
1600 kg

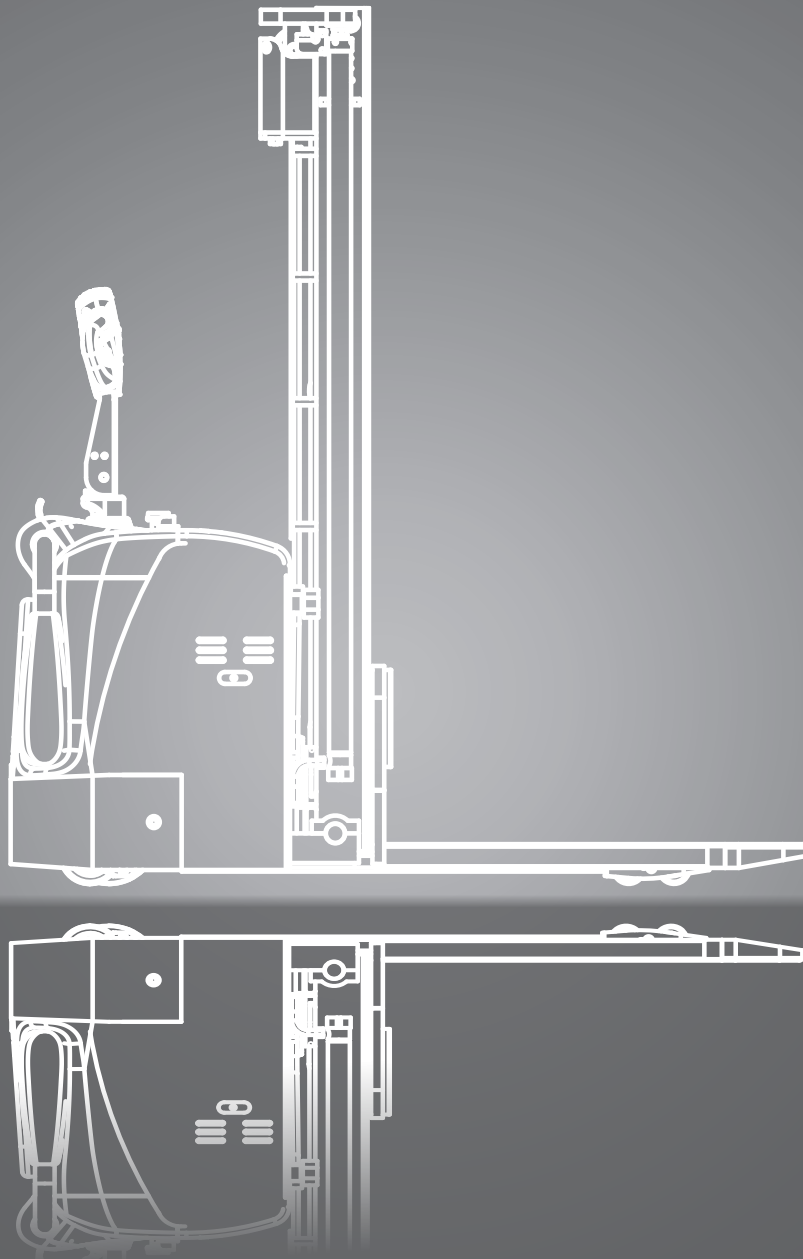

DIMENSIONS

RSE16

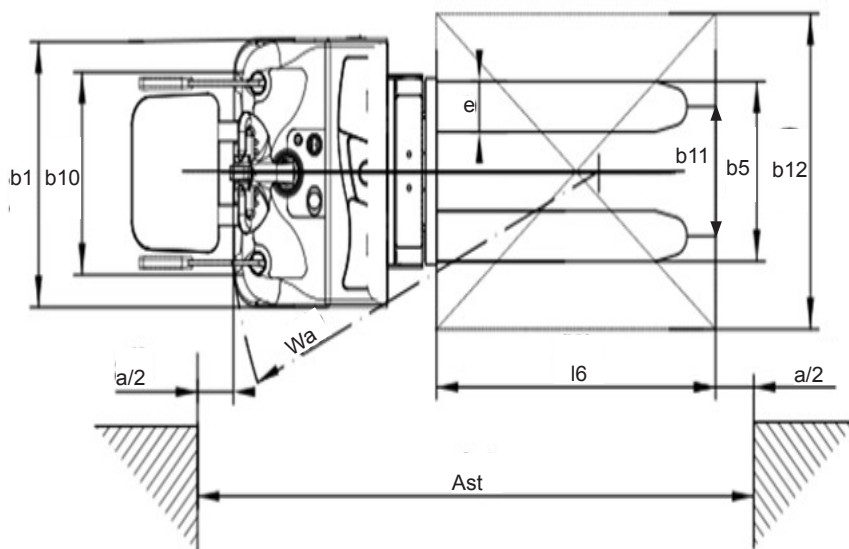
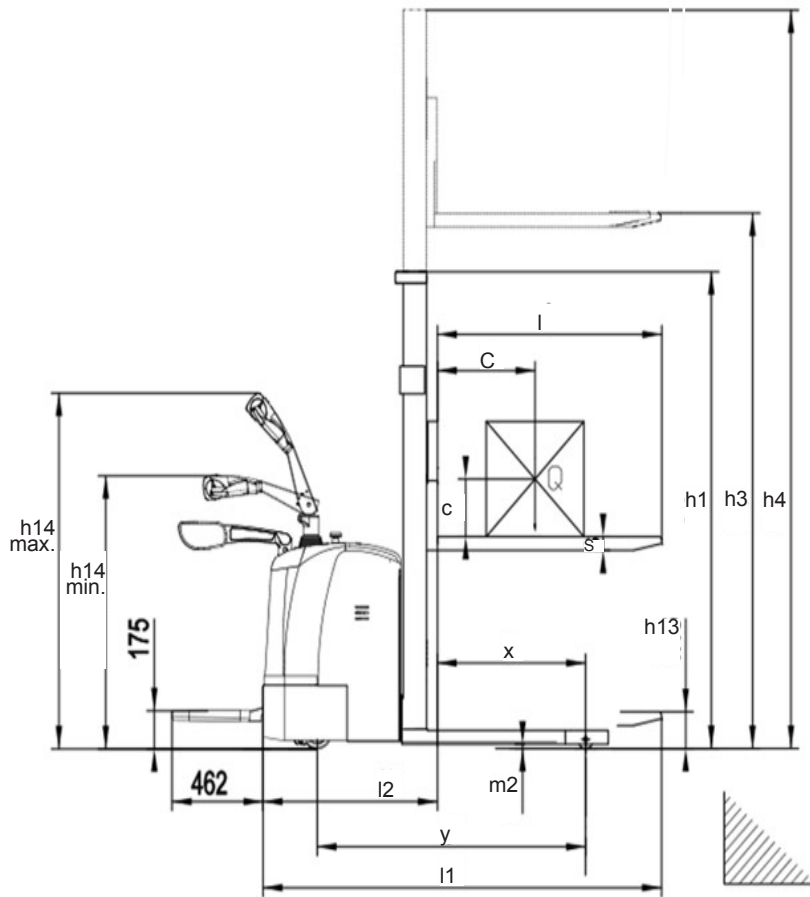

SPECIFICATIONS

Product specification acc. to VDI 2198

	1.1	Manufacturer (Abbreviation)	CLARK
Specifications	1.2	Manufacturer's designation	RSE16
	1.3	Drive unit	Electric-24V
	1.4	Operator type stand on/driver seated	Stand/Pedestrian
	1.5	Load capacity/rated load	Q (kg) 1600
	1.6	Load centre distance	c (mm) 600
	1.8	Load distance, centre of drive axle to fork face	x (mm) 672
	1.9	Wheelbase	y (mm) 1378
Weight	2.1	Service weight	kg 1510
	2.2	Axle loading, laden front/rear	kg 1830 / 1140
	2.3	Axle loading, unladen front/rear	kg 1040 / 470
Tyres, Chassis	3.1	Tyres	Polyurethane
	3.2	Tyre size, front	Ø 250 x 80
	3.3	Tyre size, rear	Ø 80 x 84
	3.4	Additional wheel (dimensions)	Ø 150 x 60
	3.5	Wheels, number front/rear (x = drive wheels)	1x+2/4
	3.6	Tread, front	b ₁₀ (mm) 580
	3.7	Tread, rear	b ₁₁ (mm) 404
Dimensions	4.2	Height of mast, lowered	h ₁ (mm) 2135
	4.3	Freelift	h ₂ (mm) 1700
	4.4	Lift height *1	h ₃ (mm) 3300
	4.5	max.height of mast, extended	h ₄ (mm) 3755
	4.9	Height drawbar in driving position min./max.	h ₁₄ (mm) 1120/1480
	4.15	Lowered fork height	h ₁₃ (mm) 90
	4.19	Overall length	l ₁ (mm) 2100
	4.20	Length to face of forks	l ₂ (mm) 950
	4.21	Width	b ₁ (mm) 850
	4.22	Fork dimensions	s*e*l (mm) 60*180*1150
	4.25	Width across forks min/max	b ₅ (mm) 570
	4.32	Ground clearance centre of wheelbase	m ₂ (mm) 31
	Performance	5.1	Travel speed laden/unladen
5.2		Lift speed laden/unladen	m/s 0.18/0.40
5.3		Lowering speed laden/unladen	m/s 0.45/0.37
5.8		max. gradeability laden/unladen (S2 5 min.) *2	% 8/15
5.10		Service brake	electro magnetic
Drive line	6.1	Drive motor output (S2 60 Min.)	kW 3.0
	6.2	Lift motor output S3 15 %	kW 4.2
	6.4	Battery voltage, nominal capacity K5	V/Ah 24/230
Misc.	8.1	Steering design	AC
	8.4	Sound level, driver's ear DIN/EN 12053	dB (A) 70

*1 At friction coefficient $\mu=0.6$ with 1.6 km/h

All values shown are for standard lift truck with standard equipment. If the truck is supplied with options, values may change. The specifications apply under normal operating conditions. All values given may vary + 5 % and - 10 % due the motor and system tolerances and represent nominal values obtained under typical operating conditions. CLARK reserves the right to change products and specifications without prior notice.

EQUIPMENT EXTRAS

	Equipment feature	RSE16
General	Low-maintenance AC drive motor	•
	Electric power steering (servo-assisted) as standard	•
	Proportional lift as standard	•
	Electric driving, lifting and lowering	•
	Battery discharge indicator	•
Battery and Charging Technology	Battery 24 V / 230 Ah Li-Ion + Charger 24 V / 100 A (external)	•
	Battery 24 V / 300 Ah Li-Ion + Charger 24 V / 100 A (external)	X
Safety and Operation	Four-wheel concept for high stability	•
	Rubber drive wheel for improved traction	X
	Fork lengths from 900 mm to 1600 mm	X
	Load backrest (1000 mm)	X
	Load backrest (1220 mm)	X
	Load backrest (1500 mm)	X
	Activation via key switch	•
	Activation via PIN-Code	X
	Turtle mode function with raised tiller arm	•
	Antistatic strap	X
	Rear view mirror	X
	A4 document holder	X
	Stretch film roll holder	X
	Scanner holder	X
	LED light (yellow)	X
	Warning signal (buzzer)	X
	Blue Light	X
Working lights	X	
Safety screen (Perspex) on the mast	•	

• = Standard equipment; x = Option

FEATURES & ADVANTAGES

RSE16

Comfortable and efficient

- Proportional hydraulic system for smooth, precise lifting and lowering
- Electric power steering (servo-assisted) as standard for controlled manoeuvring
- Low step height (175 mm) for comfortable mounting and dismounting
- Li-ion battery options (230 Ah or 300 Ah) for high availability

Operator-friendly

- Suitable for left- and right-handed users
- Ergonomically positioned controls
- Turtle mode as standard for controlled manoeuvring in narrow areas
- Multifunction colour display for operating information

Operation

- Side safety bars with soft-grip surface for secure support when cornering
- Fork length options from 1070 to 1600 mm
- Optional rubber drive wheel for improved traction
- Robust mast and frame construction
- Wide range of optional equipment
- Standard uprights 2500 - 3500 mm (with freelif)
- Triplex uprights 4500 - 5600 mm (with freelif)

Maintenance-friendly

- Easy access to components for service and maintenance
- Water- and dust-protected motor design
- CAN bus technology for simple diagnostics and reduced maintenance effort

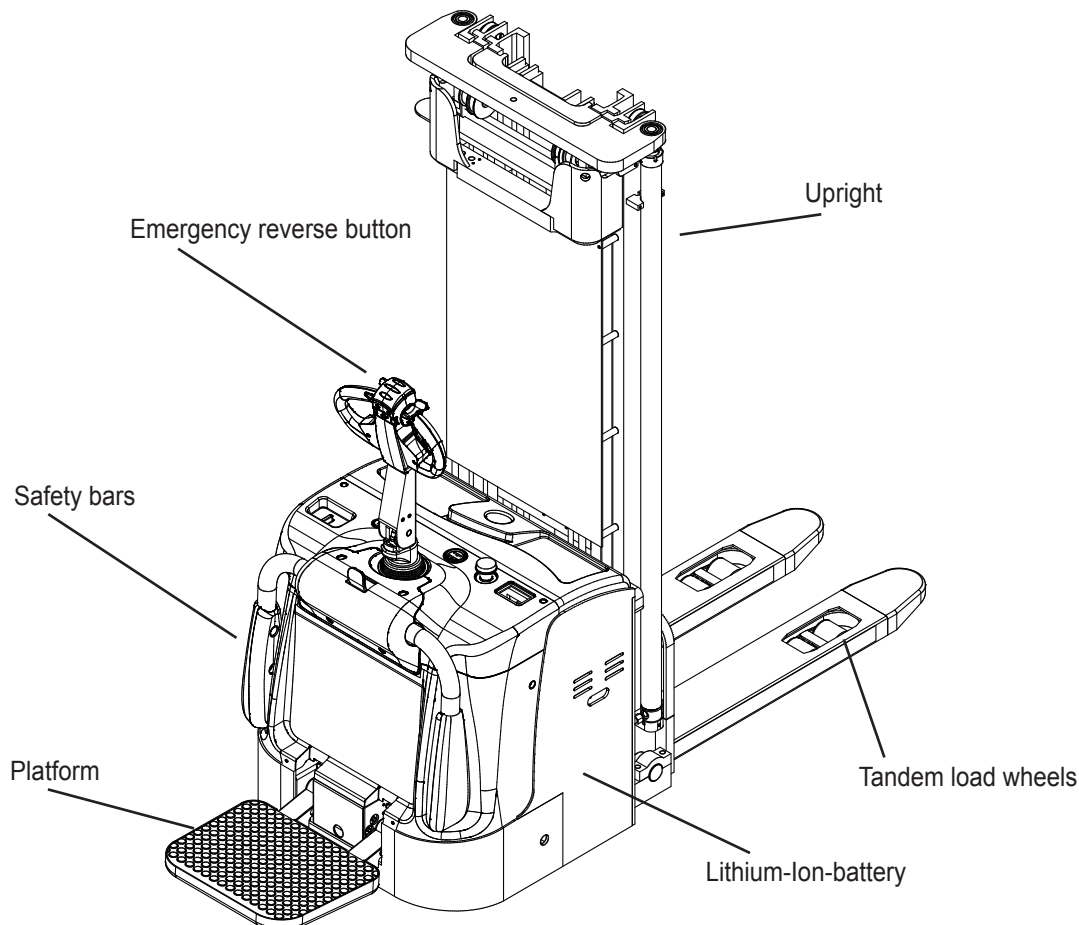

CLARK products, illustrations and specifications are subject to change without notice. Performance may vary + 5 % and - 10 % due to motor and system efficiency tolerance.

RSE16

Efficient and stable

The RSE16 is designed for comfortable and efficient work in ride-on operation. The low step height of the operator platform of just 175 mm supports frequent mounting and dismounting and helps reduce physical strain during shift work. Standard equipment includes Electric power steering (servo-assisted) as standard, providing smooth and precise handling even in narrow aisles or when transporting heavy loads.

The RSE16 is available with mast options for demanding storage and retrieval tasks in ride-on operation. Standard masts cover lift heights from 2,500 to 3,500 mm and include free lift as standard, supporting safe work in areas with low doors, gates or clearance restrictions. Triplex masts with lift heights from 4,500 to 5,600 mm are available for applications requiring higher lift heights.

The low centre of gravity supports stable and controlled handling across the full lift range. The compact chassis design supports precise manoeuvring, particularly at higher lift heights and in confined working areas.

Driving behavior & Stability

The RSE16 supports stable, controlled driving for demanding transport and storage tasks. AC control enables smooth speed regulation, while the compact truck structure and low centre of gravity support safe handling, even at higher lift heights.

The four-wheel concept provides high stability. Side safety bars give additional support, particularly when cornering or driving at higher speeds. The soft-grip surface improves comfort and grip security.

Upright table RSE16

Upright type	Lift height (h3+h13)	Built height lowered (h1)	Height upright extended (h4)		Freelift (h2)
			without load backrest	with load backrest	
	mm	mm	mm	mm	mm
Standard	2500	1735	2955	3500	1300
	3000	1985	3455	4000	1550
	3300	2135	3755	4300	1700
	3500	2235	3955	4500	1800
Triplex	4500	2050	5030	5500	1570
	5000	2210	5510	6000	1750
	5600	2410	6110	6600	1950

Dealer:

CLARK Europe GmbH
 Dr.-Alfred-Herrhausen-Allee 33
 47228 Duisburg / Germany
 Tel.: +49 (0)2065 499 13-0
 Fax: +49 (0)2065 499 13-290
 E-Mail: Info-europe@clarkmheu.com
www.clarkmheu.com