

WLE20

Lithium-Ion Powered Low Lift Pallet Truck
2000 kg

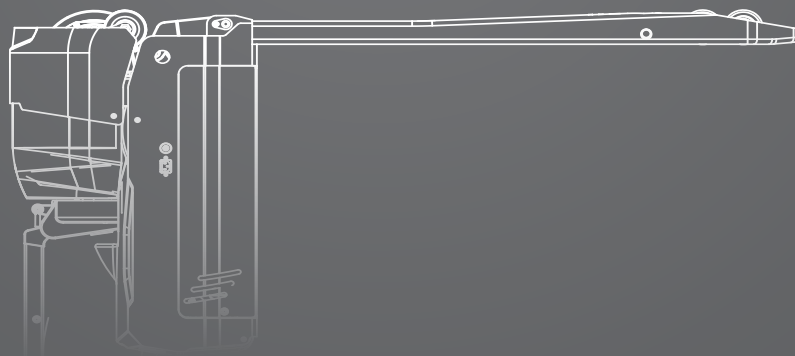
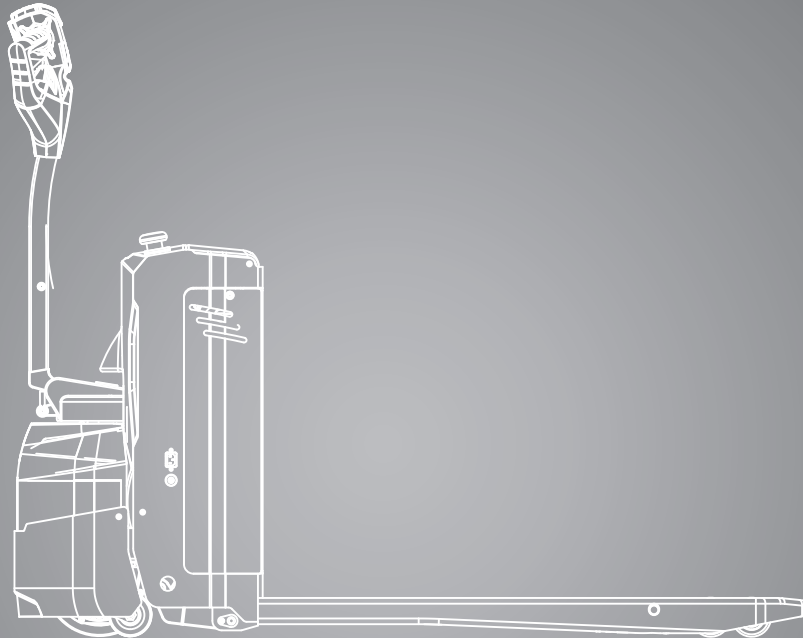

DIMENSIONS

WLE20

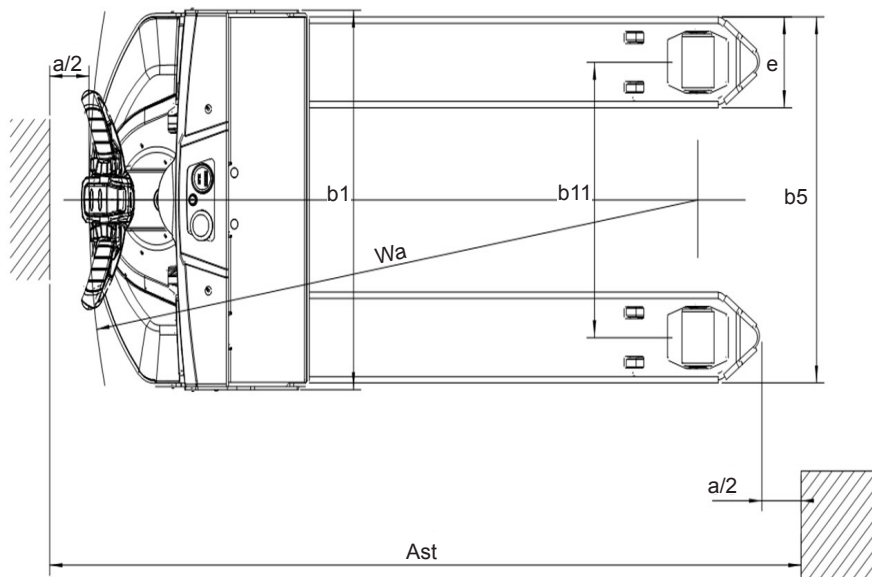
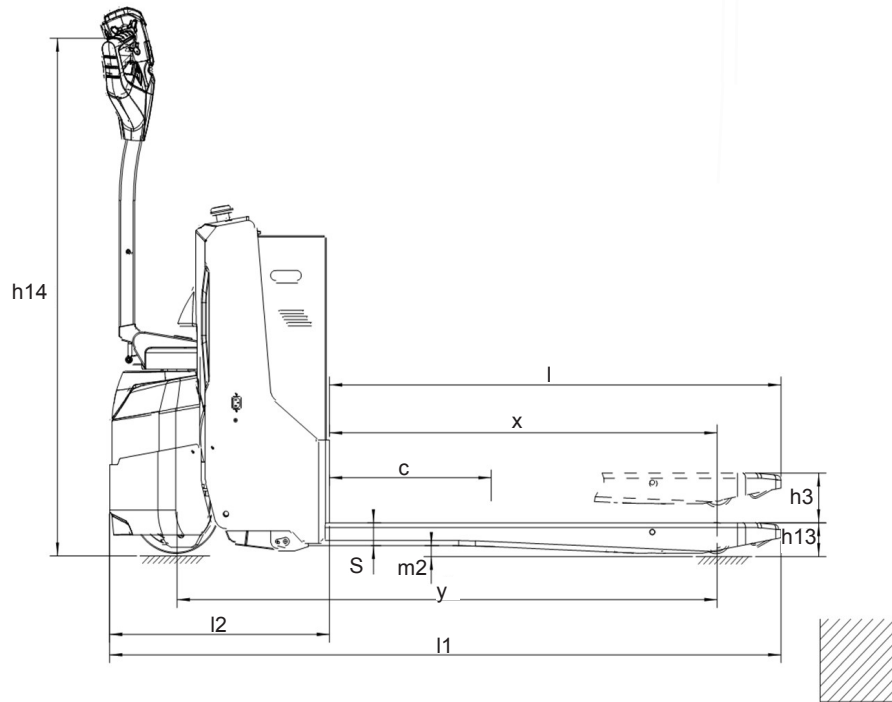

For corresponding data see specification chart.

SPECIFICATIONS

Product specification acc. to VDI 2198

	1.1	Manufacturer (Abbreviation)	CLARK
Specifications	1.2	Manufacturer's designation	WLE20
	1.3	Drive unit	Electric-24V
	1.4	Operator type stand on/driver seated	Pedestrian
	1.5	Load capacity/rated load	Q (kg) 2000
	1.6	Load centre distance	c (mm) 600
	1.8	Load distance, centre of drive axle to fork face	x (mm) 987
	1.9	Wheelbase	y (mm) 1330
Weight	2.1	Service weight	kg 340
	2.2	Axle loading, laden front/rear	kg 955 / 1385
	2.3	Axle loading, unladen front/rear	kg 270 / 70
Tyres, Chassis	3.1	Tyres	Polyurethane
	3.2	Tyre size, front	Ø 230 x 70
	3.3	Tyre size, rear (single)	Ø 78 x 106
	3.5	Wheels, number front/rear (x = drive wheels)	1x2/2 (4)
	3.6	Tread, front	b10 (mm) 478
	3.7	Tread, rear	b11 (mm) 375
	Dimensions	4.4	Lift height
4.9		Height drawbar in driving position min./max.	h_{14} (mm) 750/1250
4.15		Lowered fork height	h_{13} (mm) 78
4.19		Overall length	l_1 (mm) 1666
4.20		Length to face of forks	l_2 (mm) 516
4.21		Width	b_1 (mm) 710
4.22		Fork dimensions	s^*e^*l (mm) 74*170*1150
4.25		Width across forks min/max	b_5 (mm) 550
4.32		Ground clearance centre of wheelbase	m_2 (mm) 23
4.34.1		Stacking aisle for pallets (l6 · b12) 1000 x 1200 across	A_{st} (mm) 2302
4.34.2		Stacking aisle for pallets (l6 · b12) 800 x 1200 along	A_{st} (mm) 2156
4.35		Turning radius	W_a (mm) 1504
Performance		5.1	Travel speed laden/unladen
	5.2	Lift speed laden/unladen	m/s 0.03/0.04
	5.3	Lowering speed laden/unladen	m/s 0.04/0.03
	5.8	max. gradeability laden/unladen (S2 5 min.) *1	% 8/20
	5.10	Service brake	electro magnetic
Drive line	6.1	Service brake (S2 60 Min.)	kW 1.2
	6.2	Lift motor output S3 15 %	kW 0.8
	6.4	Battery voltage, nominal capacity K5	V/Ah 24/100
	6.5	Battery weight	kg 60
	Misc.	8.4	Sound level, driver's ear DIN/EN 12053

*1 At friction coefficient $\mu=0.6$ with 1.6 km/h

All values shown are for standard lift truck with standard equipment. If the truck is supplied with options, values may change. The specifications apply under normal operating conditions. All values given may vary + 5 % and - 10 % due the motor and system tolerances and represent nominal values obtained under typical operating conditions. CLARK reserves the right to change products and specifications without prior notice.

EQUIPMENT EXTRAS

	Equipment feature	WLE20
General	Robust steel frame construction	•
	Robust lift mechanism	•
	Adjustable push rods	•
	Electric driving, lifting and lowering	•
	Battery discharge indicator	•
Dimensions	Width across forks: 550 mm	•
	Width across forks: 685 mm	X
	Fork length: 1150 mm	•
	Fork length: 800/900/1000/1220/1500 mm	X
	Width across forks: 550 mm	•
	Width across forks: 685 mm	X
	Single fork rollers (Ø 78 mm x 106 mm)	•
	Tandem fork rollers (Ø 78 mm x 78 mm)	X
Battery and Charging Technology	Battery 24 V / 100 Ah (Li-Ion)	•
	Charger 24 V / 50 A (extern)	•
	Additional exchange batteries or chargers	X
Safety	Side support rollers	•
	Activation via key switch	•
	Activation via PIN code	X
	Load backrest (1220 mm / 48")	X
	Load backrest (1525 mm / 60")	X

• = Standard equipment; x = Option

FEATURES & ADVANTAGES

WLE20

Safe and manoeuvrable

- For demanding applications in pedestrian operation
- Two lift cylinders for even load distribution during lifting and lowering
- Compact design for narrow working areas
- Standard: side support rollers for high stability
- Optional: load backrest for additional load security

Operator-friendly

- Suitable for left- and right-handed users
- Ergonomically positioned controls
- Optional PIN code activation
- Selectable fork lengths from 800 to 1500 mm (standard: 1150 mm)

Operation

- Low fork height of just 78 mm for easy entry under pallets or low-entry load carriers
- Very good gradeability
- Precise driving control for accurate positioning
- Li-ion battery as standard
- High availability through opportunity charging

Maintenance-friendly

- Adjustable push rods
- Side support rollers with adjustable suspension
- Easy access to components for service and maintenance

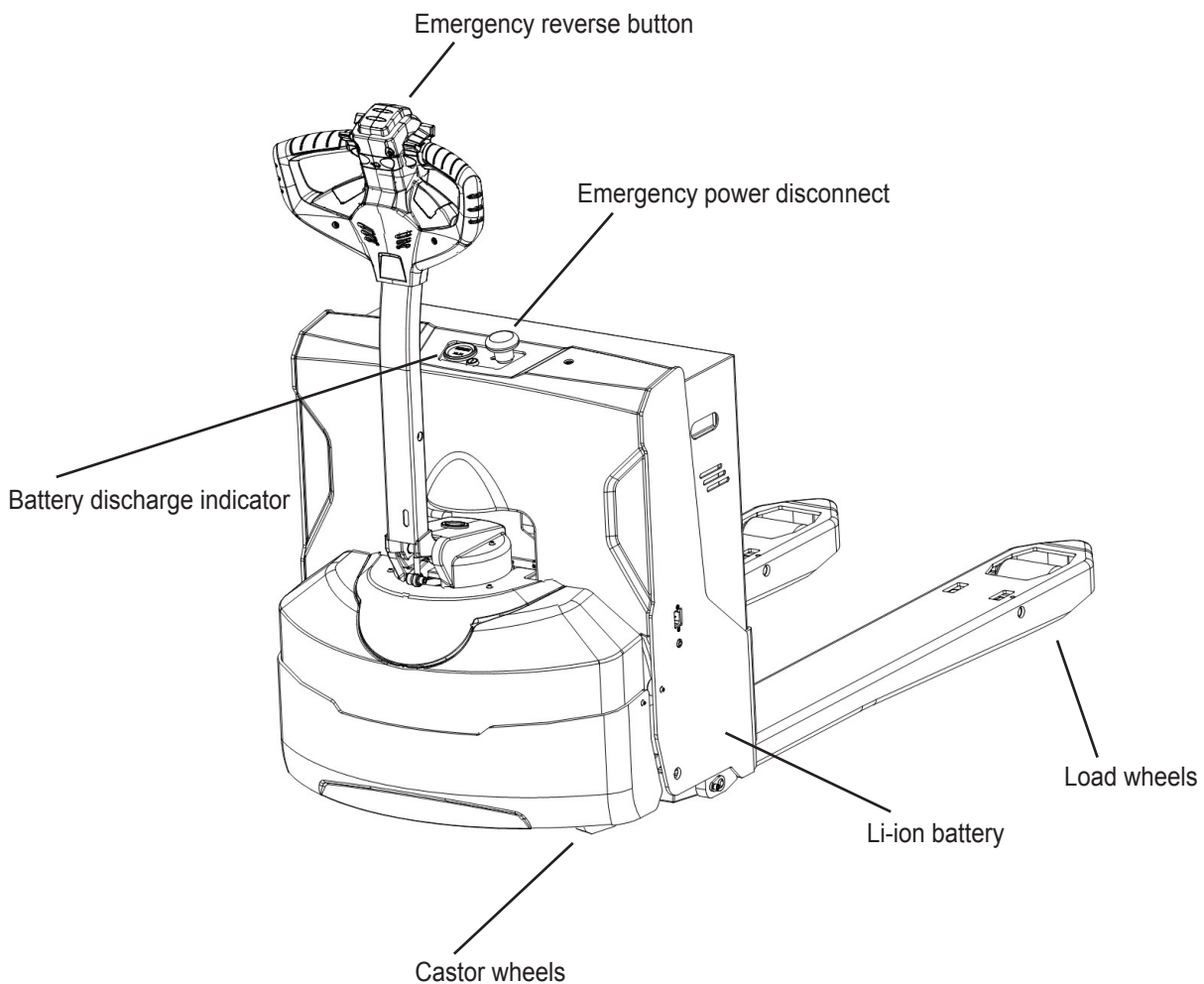

PRODUCT DESCRIPTION



WLE20

WLE20 - Powerful and manoeuvrable

The WLE20 is a powerful and manoeuvrable low lift pallet truck for demanding applications in pedestrian operation. The truck is equipped with a lithium-ion battery (24 V / 100 Ah) as standard. Two lift cylinders support even load distribution and a stable lifting process. The low fork height of just 78 mm in the lowered position makes it easy to drive under pallets or load carriers with a low entry height.

The WLE20 is particularly suitable for transporting heavy loads in goods distribution, production and warehouse logistics. Very good gradeability supports operation on ramps or uneven surfaces. Thanks to its compact design, the truck can be manoeuvred precisely in confined areas. The robust construction and high-quality drive technology support a long service life and reliable performance in daily use.

Easy Maintenance

The WLE20 features a low-maintenance design. Key components are easy to access, supporting quick daily checks and service work. A robust lift mechanism supports even lifting and helps reduce mechanical wear. The drive motor is positioned to provide protection from dirt, moisture and damage.

The WLE20 also features adjustable push rods. This allows the service technician to set the lift range and restore lift synchronisation precisely, without replacing both push rods. This reduces maintenance effort and helps lower service costs over the truck's service life.

Operator-friendly

The WLE20 is designed for efficient work in demanding conditions. The ergonomic tiller arm combines key control functions such as driving, lifting, lowering and emergency stop in a clearly laid out control area.

The truck is equipped with side support rollers as standard for stability and smooth driving behaviour. The support rollers feature adjustable suspension, allowing the service technician to set up the truck for different operating conditions. The small turning radius supports easy manoeuvring in narrow aisles, on lorry loading bays or in confined storage areas.

Optional equipment includes a load backrest for improved load security when handling higher or less stable loads. Optional PIN code activation is available for access control, which is useful for multi-shift operations or locations with changing operators.

Li-ion Technology

The WLE20 is equipped with a lithium-ion battery (24 V / 100 Ah). It supports long operating times and reliable performance. The battery is maintenance-free, durable and can be opportunity charged at any time without reducing service life. Short opportunity charges increase availability and support multi-shift operation.

With efficient Li-ion technology and an external charger, the WLE20 remains flexible, energy-efficient and cost-effective in operation.

Dealer:

CLARK Europe GmbH
Dr.-Alfred-Herrhausen-Allee 33
47228 Duisburg / Germany
Tel.: +49 (0)2065 499 13-0
Fax: +49 (0)2065 499 13-290
E-Mail: Info-europe@clarkmheu.com
www.clarkmheu.com

03/2026

Valid for Lot-no.: 13019