

WSE16/16i

Lithium-Ion Stacker Truck

Lithium-Ion Stacker Truck with initial lift
1600 kg

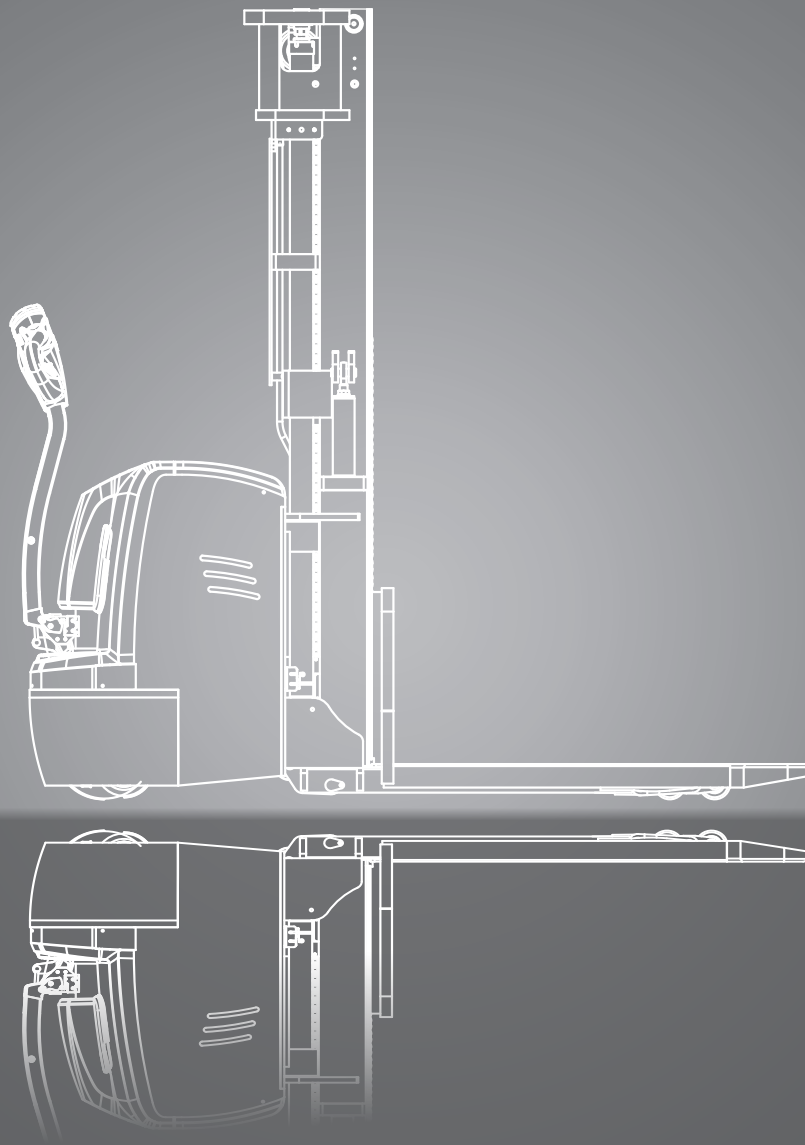

DIMENSIONS

WSE16i

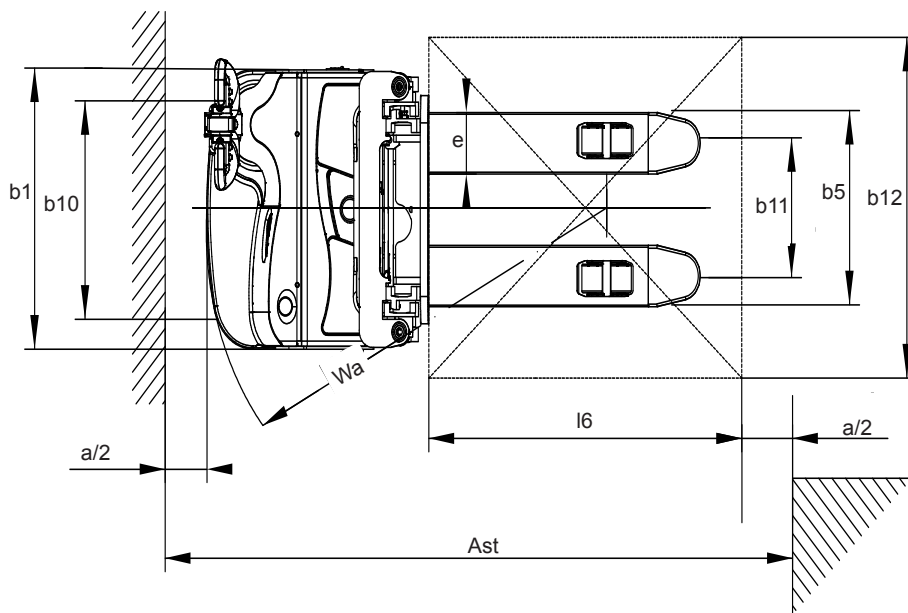
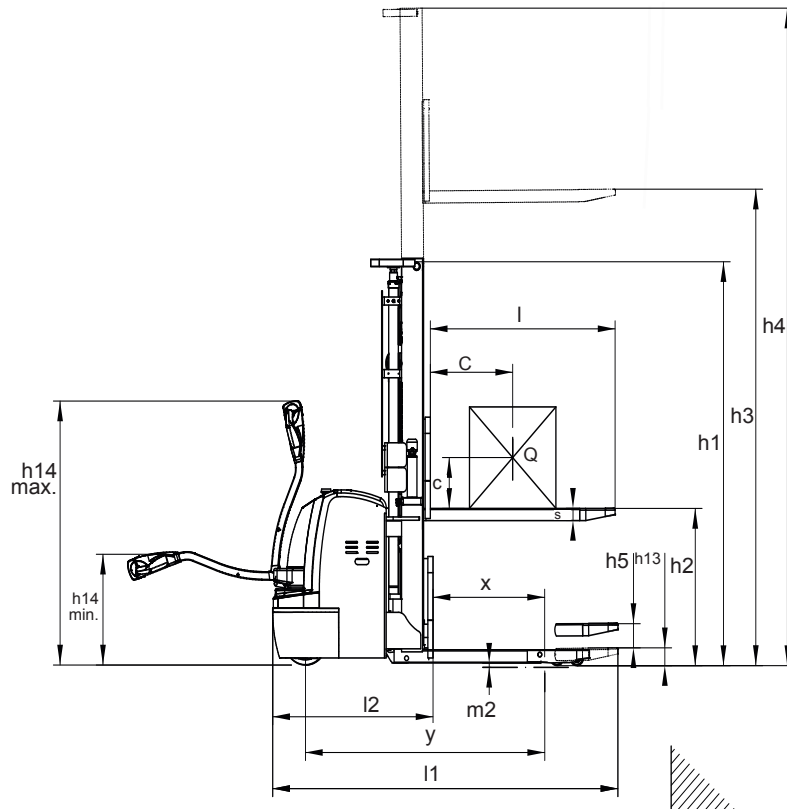

For corresponding data see specification chart.

SPECIFICATIONS

Product specification acc. to VDI 2198

	1.1	Manufacturer (Abbreviation)	CLARK	CLARK	
Specifications	1.2	Manufacturer's designation	WSE16	WSE16i	
	1.3	Drive unit	Electric-24V	Electric-48V	
	1.4	Operator type stand on/driver seated	Pedestrian	Pedestrian	
	1.5	Load capacity/rated load	Q (kg)	1600	1600
	1.6	Load centre distance	c (mm)	600	600
	1.8	Load distance, centre of drive axle to fork face	x (mm)	697	697
	1.9	Wheelbase	y (mm)	1383	1465
Weight	2.1	Service weight	kg	1220	1390
	2.2	Axle loading, laden front/rear	kg	1430 / 1270	1818 / 1134
	2.3	Axle loading, unladen front/rear	kg	843 / 356	923 / 455
Tyres, Chassis	3.1	Tyres	Polyurethane	Polyurethane	
	3.2	Tyre size, front	Ø 250 x 70	Ø 250 x 70	
	3.3	Tyre size, rear	Ø 80 x 84	Ø 80 x 70	
	3.4	Additional wheel (dimensions)	Ø 150 x 60	Ø 150 x 60	
	3.5	Wheels, number front/rear (x = drive wheels)	1x+1/4	1x+1/4	
	3.6	Tread, front	b ₁₀ (mm)	520	520
	3.7	Tread, rear	b ₁₁ (mm)	405	390
Dimensions	4.2	Height of mast, lowered	h ₁ (mm)	2135	2157
	4.3	Freelift	h ₂ (mm)	1700	1700
	4.4	Lift height *1	h ₃ (mm)	3300	3300
	4.5	max.height of mast, extended	h ₄ (mm)	3755	3777
	4.6	Initial lift	h ₅ (mm)	-	120
	4.9	Height drawbar in driving position min./max.	h ₁₄ (mm)	670/1200	670/1200
	4.15	Lowered fork height	h ₁₃ (mm)	90	90
	4.19	Overall length	l ₁ (mm)	2028	2062
	4.20	Length to face of forks	l ₂ (mm)	878	878
	4.21	Width	b ₁ (mm)	820	820
	4.22	Fork dimensions	s*e*l (mm)	60*180*1150	60*180*1150
	4.25	Width across forks min/max	b ₅ (mm)	570	570
	4.32	Ground clearance centre of wheelbase	m ₂ (mm)	31	15 - 135
	4.34.1	Stacking aisle for pallets (l6 · b12) 1000 x 1200 across	Ast (mm)	2450	2530
	4.34.2	Stacking aisle for pallets (l6 · b12) 800 x 1200 along	Ast (mm)	2420	2500
4.35	Turning radius	Wa (mm)	1575	1700	
Performance	5.1	Travel speed laden/unladen	km/h	5.0 / 5.0	5.0 / 5.0
	5.2	Lift speed laden/unladen	m/s	0.18/0.40	0.18/0.40
	5.3	Lowering speed laden/unladen	m/s	0.45/0.37	0.45/0.37
	5.8	max. gradeability laden/unladen (S2 5 min.) *2	%	8/15	8/15
	5.10	Service brake		electro magnetic	electro magnetic
Drive line	6.1	Drive motor output (S2 60 Min.)	kW	1.5	1.5
	6.2	Lift motor output S3 15 %	kW	4.2	4.2
	6.4	Battery voltage, nominal capacity K5	V/Ah	24/230	24/230
Misc.	8.1	Steering design		AC	AC
	8.4	Sound level, driver's ear DIN/EN 12053	dB (A)	70	70

*1 At friction coefficient $\mu=0.6$ with 1.6 km/h

All values shown are for standard lift truck with standard equipment. If the truck is supplied with options, values may change. The specifications apply under normal operating conditions. All values given may vary + 5 % and - 10 % due to the motor and system tolerances and represent nominal values obtained under typical operating conditions. CLARK reserves the right to change products and specifications without prior notice.

DIMENSIONS

Upright table WSE16i

Upright type	Lift height (h3+h13)	Built height lowered (h1)	Height upright extended (h4)	Height upright extended (h4)	Freelift (h2)
			without load backrest	with load backrest	without load backrest
	mm	mm	mm	mm	mm
Standard	2500	1757	2972	3500	1300
	3000	2007	3477	4000	1550
	3300	2157	3777	4300	1700
	3500	2257	3977	4500	1800
Triplex	4500	2022	4952	5500	1570
	5000	2182	5442	6000	1750
	5600	2382	6042	6600	1950

Further Options

		WSE16	WSE16i
General	Low-maintenance AC drive motor	•	•
	Initial lift (WSE16i only)	-	•
	Proportional lift as standard	•	•
	Electric driving, lifting and lowering	•	•
	Battery discharge indicator	•	•
Battery and Charging Technology	Battery 24 V / 150 Ah Li-Ion charger 24 V / 50 A (external)	x	x
	Battery 24 V / 230 Ah Li-Ion charger 24 V / 100 A (external)	•	•
Safety and Operation	4-point support for high stability	•	•
	Activation via key switch	•	•
	Activation via PIN-Code	x	x
	Rubber drive wheel for improved traction	x	x
	Load backrest: 1000 mm / 1220 mm / 1500 mm	x	x
	Turtle mode function with raised tiller arm	•	•
	Safety screen (Perspex) on the mast	•	•
	Antistatic strap	x	x
	Holder for: documents, stretch film roll, scanner	x	x
	LED light (yellow)	x	x
	Warning signal (Buzzer)	x	x
	Blue Light	x	x
Working lights	x	x	

• = Standard equipment; x = Option

FEATURES & ADVANTAGES

WSE16/16i

Precise and powerful

- Standard proportional lift for smooth and precise lifting and lowering
- High lift speeds through powerful AC technology
- Robust mast and frame construction

Operation

- Standard masts with free lift: 2,500–3,500 mm
- Triplex masts with free lift: 4,500–5,600 mm
- Turtle mode for controlled manoeuvring in narrow areas
- WSE16i: initial lift for increased ground clearance and double pallet transport
- Fork length options from 1070 to 1600 mm

Operator-friendly

- TFT colour display with clear operating information
- Optional equipment: PIN code activation, A4 document holder, scanner holder, Blue Light, load backrest
- Ergonomically positioned controls

Maintenance-friendly

- CAN bus technology for simple diagnostics
- Water- and dust-protected drive motor
- Excellent access to electrical and hydraulic assemblies

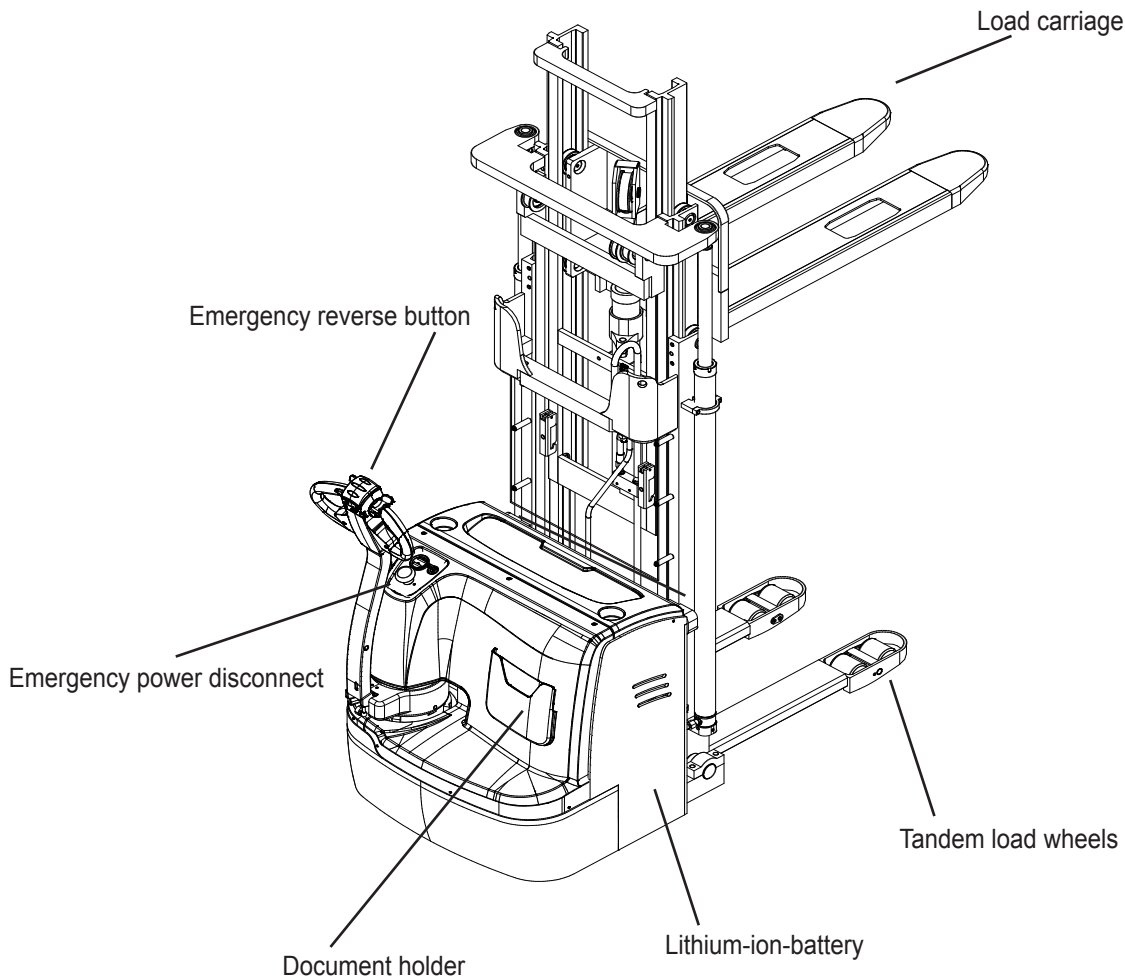

PRODUCT DESCRIPTION



WSE16/16i

Powerful and robust

The WSE16 and WSE16i models are robust electric pallet stackers for demanding industrial applications. They support fast work cycles, precise control and lift heights from 2,500 to 5,600 mm, covering a wide range of tasks in warehousing, production and logistics. Standard masts include free lift. Free lift enables the load to be lifted without changing the overall height of the truck, which is a clear advantage when working in areas with low clearance heights.

The WSE16 is the standard version without initial lift and is designed for classic storage and retrieval tasks. The WSE16i features an initial lift, providing increased ground clearance on ramps and uneven surfaces and enabling double pallet transport. This improves flexibility in the material flow.

Li-Ion Technology

The WSE16 series is available with modern lithium-ion batteries:

- 24 V / 150 Ah with external charger 24 V / 50 A (option)
- 24 V / 230 Ah with external charger 24 V / 100 A (std.)

Li-ion technology is maintenance-free and supports opportunity charging, delivering high availability for multi-shift operation. No ventilation zones or maintenance tasks such as water top-up are required.

Upright table WSE16

Upright type	Lift height (h3+h13)	Built height lowered (h1)	Height upright extended (h4)	Height upright extended (h4)	Freelift (h2)
			without load backrest	with load backrest	without load backrest
	mm	mm	mm	mm	mm
Standard	2500	1735	2955	3500	1300
	3000	1985	3455	4000	1550
	3300	2135	3755	4300	1700
	3500	2235	3955	4500	1800
Triplex	4500	2050	5030	5500	1570
	5000	2210	5510	6000	1750
	5600	2410	6110	6600	1950

Dealer:

CLARK Europe GmbH
 Dr.-Alfred-Herrhausen-Allee 33
 47228 Duisburg / Germany
 Tel.: +49 (0)2065 499 13-0
 Fax: +49 (0)2065 499 13-290
 E-Mail: Info-europe@clarkmheu.com
www.clarkmheu.com

Valid for Lot-no. WSE16: 13034
 WSE16i: 13017